

REFRIGERATOR FEATURES AND SPECIFICATIONS

STUDIO SIZE

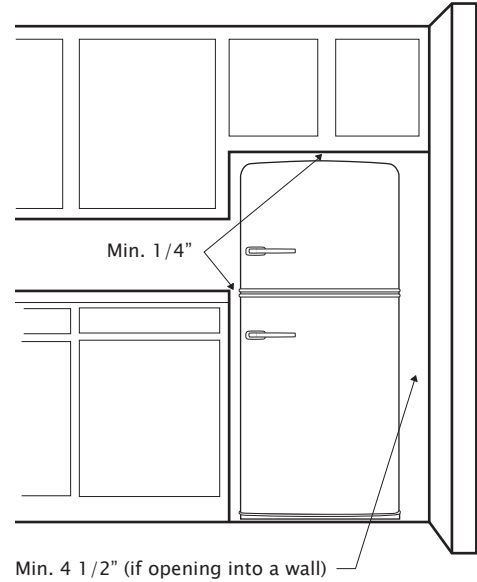
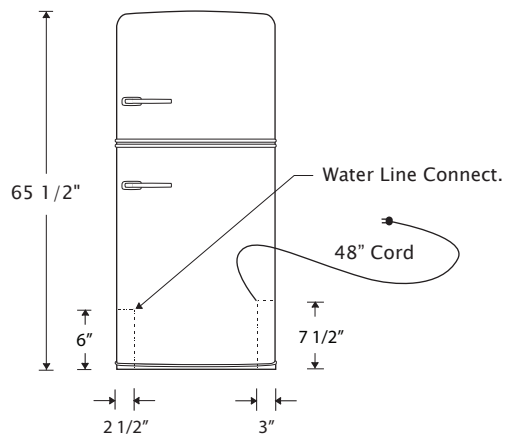
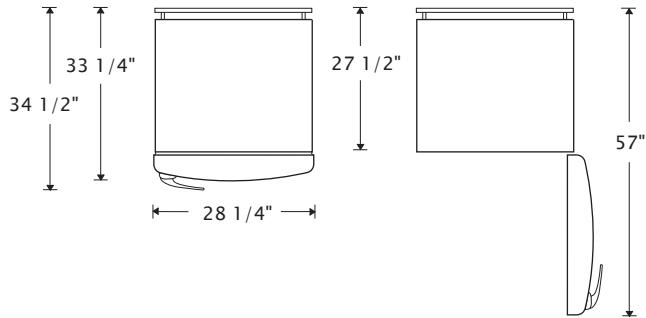

Total Capacity	14.4 cu. ft.
Refrigerator Capacity	10.6 cu. ft.
Freezer Capacity	3.8 cu. ft.
Clearance: Back	1/2"
Clearance: Side	1/4"
Side Clearance for door to open 90°	4 1/2"
Adjustable Rollers	Standard
Energy Guide (kWh/year)	373
Electrical	115V, 60Hz, AC only, 15 or 20 amp fused
Shipping Weight	300 lbs

FEATURES:

Stamped Metal Body, Chrome Trim, 2 Half-Width Crisper Drawers, Adjustable Shelving, Available Left Hand Hinge, Optional Ice Maker



WEB: bigchill.com

EMAIL: sales@bigchill.com

PH: 877-842-3269